

## 1.0 DESIGN

### 1.1 PRECAUTIONS

Automatic Valve Corp. products are general purpose industrial pneumatic and vacuum devices. They are not themselves inherently harmful. However, the control systems in which they operate must have necessary safeguards to prevent injury or damage should failure of system components occur.

Use Automatic Valve Corp. products only within the operating specifications stated for the product in each catalog section or on the drawing.

Read and be familiar with the precautions listed under the Design, Installation, Maintenance, and Troubleshooting portions of the catalog or D7179-004. Provide adequate warnings and information on system components and in system operating manuals.

**Power Presses:** Do not use Automatic Valve Corp. for power presses. Automatic Valve Corp. does not manufacture the special purpose dual safety clutch and brake valves required by OSHA Regulation 1910.217, dated November 1, 1975, and ANSI Standard B11.1, Revision 1982, and EN 13736: 1999.

**Two Position Valves:** Two position 2 and 3-way valves will have a flow path from the valve's inlet port to one of the valve's outlet ports in either one or both of the two positions. 4-way valves will always have a flow path from the inlet to one of the outlet ports regardless of its position. If retaining pressurized air in the system presents a hazard during system operation or servicing, a separate method must be used to exhaust the trapped air.

**Three Position Valves:** Solenoid operated and air piloted three position 3-way and 4-way valves will move to the center position if one of the operators is not actuated. Manually operated three position valves may or may not return to the center position, depending on the centering operator. When one of the operators is actuated, a flow path will exist as it does in two position valves. When the valve is in the center position, the flow path described below exists.

**Block Center:** All ports, including inlet and exhaust ports, are blocked when the valve is in the center position. If trapping air in either or both of the valve outlet cylinder ports presents a hazard during system operation or servicing, a separate method must be used to exhaust the trapped air or the valve should not be used.

**Caution:** *Valves with blocked centers should be used with discretion because there is no makeup air. Any leaks in the valve, cylinder, or system lines and fittings can cause drifting (movement) of the cylinder.*

**Exhaust Center:** When the valve is in the center position, the inlet port is closed and the cylinder ports are open to exhaust ports. If this condition is hazardous in either operation or during servicing, the valve should not be used.

**Pressure Center:** When the valve is in the center position, the inlet port pressurizes the cylinder ports and the exhaust ports are blocked. If this condition is hazardous in either operation or during servicing, the valve should not be used.

**Solenoid Manual Overrides:** Some Automatic Valve Corp. air piloted and solenoid operated valves incorporate manual overrides which, when actuated, shift the valve as if the solenoid or air pilot were actuated. If accidental or intentional operation of the manual override could cause a dangerous problem, the valve should be ordered without a manual override.

---

## 2.0 OPERATION

Refer to operating specifications in the catalog or the drawing for notes 5 – 8, functional flow diagrams, and the schematic.

---

## 3.0 INSTALLATION

### 3.1 PRECAUTIONS

Automatic Valve Corp. products should only be installed by trained and qualified personnel who have knowledge of how specific pneumatic products are to be piped and electrically connected.

Install Automatic Valve Corp. products only in systems which contain adequate safeguards to prevent injury or damage in the event of product failure.

Ensure that the system has provisions for turning air and electrical power off and for exhausting all air trapped within the system.

### 3.2 OPERATING MEDIA

Automatic Valve Corp. products are designed primarily for use with air or other inert gases. For use with other media, contact your Automatic Valve Corp. distributor.

When solenoid piloted valves are used for vacuum service, an external pilot supply must be used.

### 3.3 AIR LINES

Before installing any pneumatic product, air lines should be blown clean to remove all contamination. Clean air line filters after purging is completed.

**Caution:** *Compressed air streams are dangerous. Divert the stream away from personnel and equipment. Personnel in the area must wear suitable eye and ear protection.*

### 3.4 PIPE AND FITTING PREPARATION

Automatic Valve Corp. recommends the use of pipe sealant instead of Teflon tape when making connections to NPT ports. The sealant used by Automatic Valve Corp. is specified in the bill of materials on the drawing.

Pipe sealant should be applied behind the first two or three threads to prevent the sealant from entering and contaminating the system.

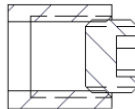

While no torque values are available for NPT fittings, a general rule of thumb is to install the fitting hand tight and then turn an additional 1 to 1 ½ turns.

### 3.5 MOUNTING

Spool valves must be mounted with the spool in a horizontal position. Other valves, cylinders, and accessories may be mounted in any position.

Refer to dimensional data in the catalog or on the drawing.

Where practical, mount valves so that they are accessible for service and so that solenoid manual overrides can be used if applicable.

### 3.6 VALVE INLET LINES

Valve inlet lines should have an inside diameter equal to or greater than the valves' inlet port size as shown in the following chart:

INLET TAP SIZE	SUPPLY ID (MIN.)	INLET TAP SIZE	SUPPLY ID (MIN.)
1/8 NPT	.25"	3/4 NPT	.75"
1/4 NPT	.38"	1 NPT	1.00"
3/8 NPT	.50"	1 1/4 NPT	1.25"
1/2 NPT	.63"	1 1/2 NPT	1.50"

Restricted inlet lines will reduce the system operating speed and can cause valve malfunction. Eliminate or minimize sharp bends and install regulators as close as possible to the valve inlet port.

### 3.7 VALVE OUTLET LINES

For optimum system performance, locate valves as close as possible to the device they are operating. Minimize all sharp bends and other restrictions. If bench testing the valve, ensure a load chamber is installed.

### 3.8 VALVE EXHAUST PORTS

Spool valve exhaust ports may be restricted to provide speed control for cylinders or other devices.

Poppet valve exhaust ports must NOT be restricted. Such restriction can cause valve malfunction.

All open valve exhaust ports should have full flow (not flush mounted) mufflers installed to reduce noise levels and to prevent the entry of atmospheric contamination or directed downward with elbows to prevent the entry of atmospheric contamination.

### 3.9 FILTRATION

Filters with 50 micron elements are adequate for all Automatic Valve Corp. products. However, where devices not made by Automatic Valve Corp. are used in the system, the manufacturer should be consulted regarding their filtration requirements.

Install filters within 20 feet of the valve or per the manufacturer's instructions.

### 3.10 OPERATING PRESSURES AND TEMPERATURES

Minimum and maximum operating pressures and temperatures for Automatic Valve Corp. products are specified in each catalog section or notes 5 – 8 on the drawing. While products may function at lower or higher limits, such operation is unsafe and must be avoided.

Contact your Automatic Valve Corp. distributor if your application requires products that exceed the operating limits shown.

### 3.11 PILOT PRESSURE

For proper operation, pilot pressure must be within the minimum and maximum operating pressures shown in each catalog section or notes 5 – 8 on the drawing.

If solenoid piloted valves are to operate at lower or higher operating pressures than the specified pilot pressure limits, an external pilot supply within the proper pressure range must be used. Valves may either be ordered with an external pilot supply, option "B", or may be field converted as shown in each catalog section or on the drawing.

### 3.12 LUBRICATION

Automatic Valve Corp. products are pre-lubed at the factory. Components that are pre-lubed and the pre-lube material are noted with a '+' in each catalog section or in the bill of materials on the drawing.

Lubrication of Automatic Valve Corp. products is not required, but it recommended to maximize service life. Where devices not made by Automatic Valve Corp. are used in the system, the manufacturer should be consulted regarding their lubrication requirements.

Lubricators should be installed downstream of regulators, per the manufacturer's instructions.

Oils used in air line lubricators should be compatible with seals used in the system. Generally, Automatic Valve Corp. products use Fluoroelastomer seals. Oils should be paraffinic, petroleum based with oxidation inhibitors, an ISO 32 or lighter viscosity, and an aniline point between 82°C (180°F) and 99°C (210°F).

In general, lubricators should not be synthetic or reconstituted, and should not have alcohol content or detergent additives.

## 4.0 TROUBLESHOOTING

All products shipped from the AVCO factory are 100% function and leak tested and are tested to additional PO and QA program requirements, as applicable. The following issues will not occur on new products. However, if customer application or other activities create these situations, the following are guidelines for how to address.

### 4.1 PRECAUTIONS

Read and follow the precautions listed in the Maintenance section of the catalog or D7179-004. Stay clear of all moving parts that must be actuated when troubleshooting.

### 4.2 GENERAL COMMENTS

Of all the components in an electrical / mechanical / pneumatic system, it is most often the control valve that will be faulted for system malfunction. In many cases, the valve is only the symptom of the problem. Leaking cylinder seals, poor electrical connectors, clogged air line filters, and broken or jammed mechanical components are just a few of the problems that can initially be diagnosed as a valve problem.

Before disassembling any system component, use the following troubleshooting guide to try to pinpoint the exact cause of the problem.

PROBLEM	POSSIBLE CAUSE	REFERENCE SECTION
<b>Valve leaks to exhaust Not Actuated</b>	Defective cylinder or valve seals	4.3
<b>Valve leaks to exhaust Actuated</b>	Defective cylinder or valve seals Inadequate air supply Inadequate pilot supply Contamination	4.3 4.4 4.5 4.6 & 4.7
<b>Solenoid pilot leakage</b>	Dirt on seats or seal wear	4.8
<b>Operator vent leaks</b>	Worn piston seal Damaged cap seal	4.9 4.9
<b>Sluggish operation</b>	Contamination Inadequate air supply Inadequate pilot supply Improper or clogged muffler Inadequate or improper lubrication Mechanical binding	4.6 & 4.7 4.4 4.5 4.10 4.11 4.17
<b>Poppet valve chatter</b>	Inadequate air or pilot supply Contamination Improper or clogged muffler Inadequate or improper lubrication	4.4 & 4.5 4.6 & 4.7 4.10 4.11
<b>Solenoid buzzes or solenoid burnout</b>	Incorrect voltage Faulty or dirty solenoid	4.12 4.13
<b>Solenoid valve fails to shift electrically but shifts with manual override</b>	Incorrect voltage Override left activated Defective coil or wiring	4.12 4.14 4.15
<b>Solenoid valve fails to shift electrically or with manual override</b>	Inadequate air supply Inadequate pilot supply Contamination Inadequate or improper lubrication Mechanical binding	4.4 4.5 4.6 & 4.7 4.11 4.17
<b>Valve shifts but fails to return</b>	Broken spring Mechanical binding	4.16 4.17

### 4.3 VALVE EXHAUST PORT LEAKAGE

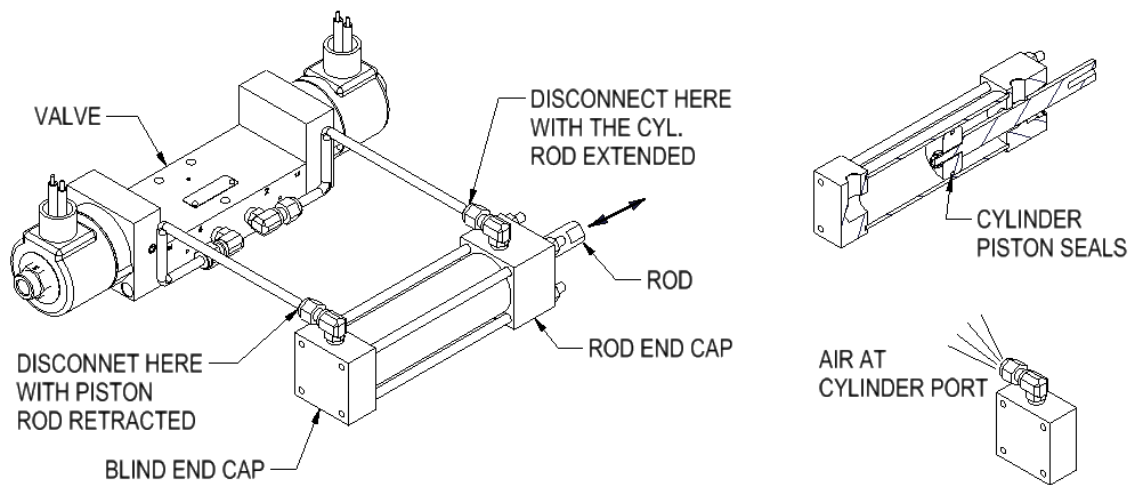

Verify if the leakage is caused by the cylinder or valve as follows: (Use extreme caution as the valve and cylinder will both be actuated during this procedure.)

1. With the piston rod retracted, disconnect the line at the cylinder blind end cap. If air comes out of the cylinder port fitting, as shown above, the cylinder piston seals are defective and must be replaced. If there is no leakage, reconnect the line.
2. With the cylinder rod extended, disconnect the line at the cylinder rod end cap. If there is leakage at the cylinder port fitting, the cylinder piston seals must be replaced.
3. If there is no leakage at the fitting, the leakage is caused by defective valve seals or gaskets. Contact the factory.

### 4.4 INADEQUATE AIR SUPPLY

An inadequate air supply can cause the pilot supply pressure to drop during valve actuation. This can result in valve chatter or oscillation, particularly in poppet valves, or may keep the valve in a partially shifted condition where it continually blows to exhaust. If the pressure gage falls by more than 10% during valve actuation, there is probably a deficiency in the air supply system.

1. Air line filters should be cleaned, and pressure regulators checked for proper operation. The line sizing recommendations in the Installation section should be reviewed and modifications made if restrictions or undersize inlet lines are found.
2. Verify that the air compressor has sufficient capacity to meet all systems requirements.

### 4.5 PILOT SUPPLY

Remote air pilot signals or pilot supplies to externally piloted solenoid valves that are restricted or are below the minimum operating pressures can cause valve oscillation or partial actuation resulting in exhaust port leakage.

1. Verify that the operating signal is at the proper pressure and that there are no restrictions caused by clogged filter elements or improperly sized pilot lines.
2. Comments in 4.4 also apply to pilot supplies.

#### 4.6 LIQUID CONTAMINATION

Accumulation of oil and water at low points in the system, including valves, can cause erratic or sluggish performance and exhaust leaks.

1. If heavy concentrations of water or oil are found when a device is disassembled, it should be thoroughly cleaned, re-lubricated and reassembled.
2. Filters and lubricators should be cleaned and checked for proper operation. If necessary, air lines should be rerouted to eliminate low points.
3. If there are concentrations of moisture at below freezing temperatures, ice can form and cause erratic operations, or completely bind system components. In such situations, steps must be taken to dry the air to a dew point of at least 10°F below the minimum system operating temperature. Also, filters should be equipped with automatic drains.

#### 4.7 SOLID CONTAMINANTS

Solid contaminants, such as broken pieces of pipe threads, pipe sealant or tape, or rust scale, can cause valve seal damage, scratches on spools and sealing surfaces, or system binding and possible exhaust leaks. Such problems are most often encountered in new installations that have not been properly purged or where there are heavy concentrations of atmospheric contaminants.

1. In many cases, cycling the valve several times will flush the particles away. If not, the item must be disassembled and the parts thoroughly examined for signs of damage and replaced as necessary.
2. Before reinstalling the product, the air line should be purged as stated in the Installation section. Air line filters should be cleaned and checked for proper operation. Properly sized mufflers should be installed in valve exhaust ports.

#### 4.8 SOLENOID PILOT LEAKAGE

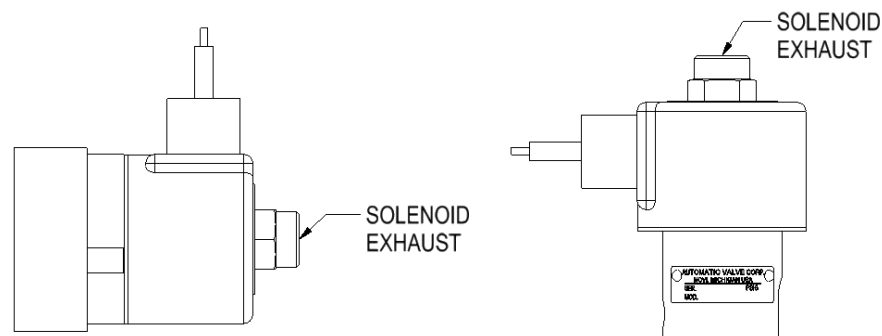

Continuous leakage from the operator exhaust port when the solenoid is de-energized can be caused by a foreign particle trapped between the bottom seat and the plunger, by a damaged bottom seat, or by a worn or damaged bottom plunger seal.

Leakage at the exhaust port and/or solenoid buzzing when the solenoid is energized can result from a foreign particle lodged in the top seat area. Leakage in this area can also be caused by worn or damaged top seats or top plunger seals. Contact the factory.

#### 4.9 OPERATOR VENT LEAKS

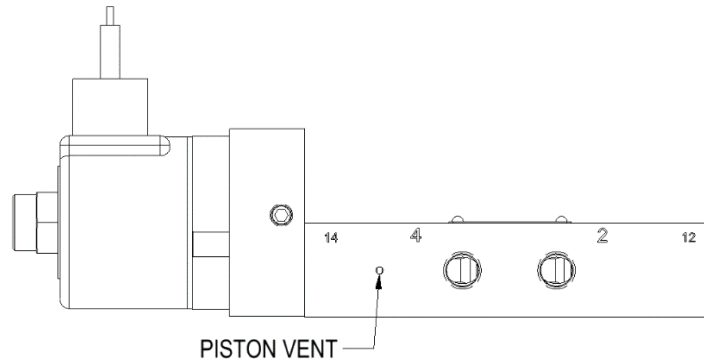

Vent leakage when the solenoid is energized can be caused by either a faulty operator piston or cap seal. Contact the factory.

#### 4.10 MUFFLERS

Mufflers that are undersized for the application or that have become clogged can cause slow system response or, in the case of poppet valves, system malfunction or valve oscillation.

1. Remove the muffler and cycle the valve several times to see if it operates satisfactorily without the muffler.
2. If it does, the muffler should be cleaned or, if it is not dirty, replaced with a larger muffler with adequate exhaust flow capacity.

#### 4.11 IMPROPER LUBRICATION

Air line lubricators that are not set at the proper flow rate or that contain lubricants not compatible with seals can cause sluggish system performance or malfunction.

1. If oil mist can be seen in the exhaust air, if films of oil are in evidence on surfaces around exhaust ports, or if pools of oil are found in valves or other devices, the lubricator is set at too high a flow rate. As a general rule, a flow rate of one drop per minute is adequate to provide a thin film of oil on moving surfaces.
2. If the flow rate is too low or the reservoir is empty, system elements that require lubrication can slow down or even bind. Lubricator reservoirs should be filled on a scheduled basis and the proper lubricator flow rate maintained.
3. Compatibility of the lubricating oil with system seals should also be verified, as stated in the Installation section. Incompatible lubricants can cause seals to swell which can result in sluggish performance or even binding of moving parts.

#### 4.12 INCORRECT SOLENOID VOLTAGE

Automatic Valve Corp. solenoids are designed to operate between 90% to 110% of the rated voltage shown on the solenoid coil. A supply voltage that does not fall within the range shown can cause solenoid buzzing, failure of the valve to shift, or coil burnout.

1. To verify proper voltage, shut off and exhaust the air supply to the valve.
2. Attach a voltmeter to the solenoid's electrical supply, energize the solenoid, and note the voltage reading. If the reading is too low, the electrical supply is inadequate and must be corrected.

#### 4.13 FAULTY OR DIRTY SOLENOID

Improper voltage, broken or damaged shading rings, or dirt on the plunger or around the top seat can cause solenoid buzzing or even coil burnout. If this should occur, contact the factory.

#### 4.14 MANUAL OVERRIDE LEFT ACTUATED

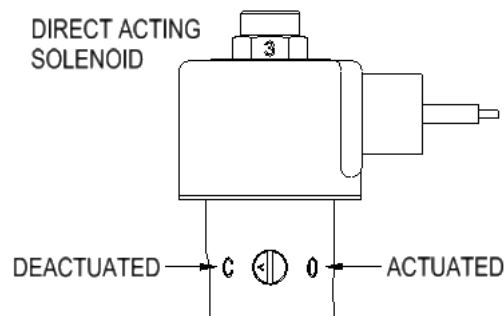

If a turn locking manual override is left in the actuated position, the valve will operate when the override is again cycled, from on to off and back to on, but will fail to operate electrically. This happens because the override is holding the plunger in its actuated position.

1. Verify that locking type overrides are in their normal deactuated position and that non-locking overrides have not become stuck.

#### 4.15 DEFECTIVE COIL OR WIRING

Coils used by Automatic Valve Corp. seldom burn out when operated within listed voltage limits.

1. Verify that the operating voltage is correct per 4.12.
2. Verify that wash-down applications have not caused thermal shock.
3. Verify the integrity of the coil by shutting electrical power off and using an ohmmeter to check continuity. If the coil is open, it is burned out and must be replaced. If there is coil continuity, the electrical system should be checked for loose or broken connections and for worn or defective switches and contacts.

#### 4.16 BROKEN SPRING

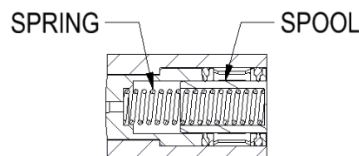

Broken springs on spring return valves can cause a valve to remain in the actuated position or to only partially return and perhaps leak to exhaust.

1. Broken springs must be replaced. Contact the factory.

#### 4.17 MECHANICAL BINDING

Mechanical binding of cylinders or other mechanical components can cause symptoms that can be improperly diagnosed as sluggish valve operation or even failure of a valve to shift. If a valve appears stuck, note the flow from the valve exhaust ports as the valve is actuated or deactuated. If there is a puff of air from each exhaust port, yet the device fails to move, the probable cause is mechanical binding.

1. Turn air and electrical power off.
2. Follow all safety precautions recommended by the manufacturer of the equipment.
3. Make mechanical inspections and adjustments as required.



## 5.0 MAINTENANCE

### 5.1 PRECAUTIONS

Automatic Valve Corp. products should be serviced only by qualified and knowledgeable personnel who understand the function and operation of the product.

Before servicing any pneumatic system, verify that the air and electrical power are **off** and that all air within the system has been exhausted.

Take all necessary precautions to prevent degradation of products caused by stepping on them, dropping them, or hitting them with a hammer or other object.

Return products damaged as a result of improper handling to Automatic Valve Corp. for inspection.

### 5.2 PREVENTATIVE MAINTENANCE

Install all pneumatic systems as described in the Installation section. Improper installation can cause sluggish system performance and, if contaminants are not purged, premature wear of components.

Drain, clean, and service air line filters on a periodic basis or as recommended by the manufacturer.

Adjust air line lubricators per the manufacturer's recommendations (generally, one drop per minute) and fill the reservoir at scheduled intervals. When filling the reservoir, use lubricating oils as prescribed under the Installation section.

To avoid possible solenoid malfunction, keep all electrical switches and relay contacts in good condition.

Automatic Valve Corp. products are designed to operate in normal air system environments with a minimum of maintenance. In extreme conditions, as evidenced by sluggish performance or sticking problems, a periodic program for cleaning internal product components should be established.

To clean products, use a water-soluble detergent. To avoid component damage, do not use abrasive compounds or scrape metal parts.